

► DESCRIPTION

UCAN UTB TZ Patented Aster Thread TORPEDO BOLT is an excellent anchoring solution for medium-duty applications. TORPEDO® Bolt screw anchors are comprised of a body with a hex flange head. The anchor is manufactured from carbon steel and is heat-treated. It features a 0.0021-inch (53 µm) Mechanical galvanized zinc coating, as per ASTM B695, Class 65, Type 1. TORPEDO® Bolt screw anchors are used as anchorage to resist static, wind, and seismic (Seismic Design Categories A through F) tension and shear loads in cracked and uncracked average weight and lightweight concrete having a specified compressive strength, f'_c , of 2,500 psi to 8,500 psi (17.2 MPa to 58.6 MPa).

The anchor is tested by an accredited testing agency (American Association for Laboratory Accreditation) in compliance with:

- ASTM E488 ("Standard Test Methods for Strength of Anchors in Concrete and Masonry Elements")
- ICC-ES AC193 ("Acceptance Criteria for Mechanical Anchors in Concrete Elements")
- ACI 355.2 ("Qualification of Post-Installed Mechanical Anchors in Concrete")

UTB TZ TORPEDO® BOLT has been evaluated by an accredited independent agency (ICC-ES) for recognition of use in cracked and uncracked concrete, including seismic and wind loads in concrete members having a specified compressive strength, f'_c , from 2,500 psi to 8,500 psi (17.2 MPa to 58.6 MPa). The UTB TZ TORPEDO bolt is listed in the ICC-ES Report ESR4596.

Matched with a standard UCAN ANSI tolerance drill bit, this fastener exhibits consistently high load values. The UCAN TORPEDO® BOLT installs quickly using the UCAN TST Installation Driver, leaving the working surface with the clean appearance of a finished hex washer head.

► FEATURES

- Use with UCAN standard ANSI compliant drill bit
- Fast installation and reduced edge distance requirements, compared to mechanical expansion anchors.
- One piece fastener with finished hex flange head and locking under-head serration
- Unique thread pattern facilitates ease of installation
- Anchor can be set with an impact or manual socket wrench.
- Removable—Ideal for temporary anchoring applications.
- Anchor size is stamped on head for easy identification and enhanced quality control after anchor installation.

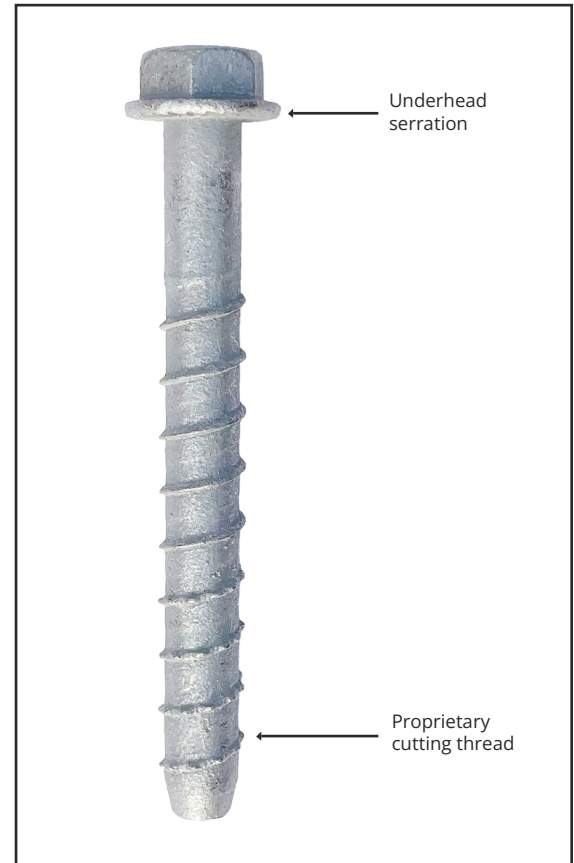

► LISTING AND APPROVALS



ICC-ES®
ESR 4596

UTB 38134, UTB 38212,
UTB 383, UTB 384, UTB 385,
UTB 12212, UTB 123, UTB 124,
UTB 125, UTB 126

► TYPICAL APPLICATIONS

- Racking, Railing, Sill plates, Stadium seating.
- Anchoring equipment

► LIMITATIONS

Not recommended for installation into uncured concrete (less than 7 days old).

► MATERIAL SPECIFICATIONS

Properties	Carbon Steel
Anchor body	Heat treated carbon steel
Head style	Hex flange head with locking serrations
Corrosion protection	Mechanically galvanized as per ASTM B-695, Class 55, Type 1

► INSTALLATION INFORMATION

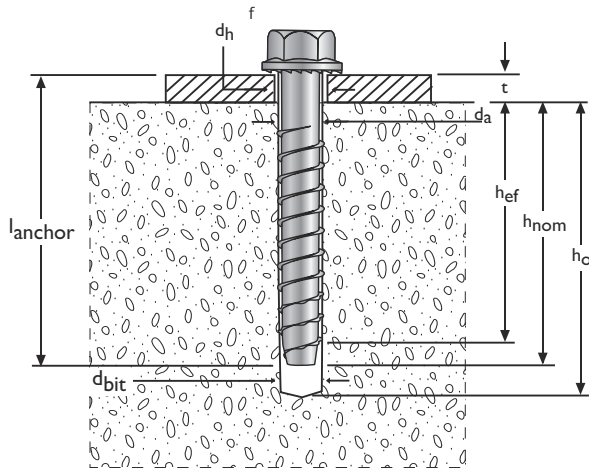

► INSTALLATION INSTRUCTION¹

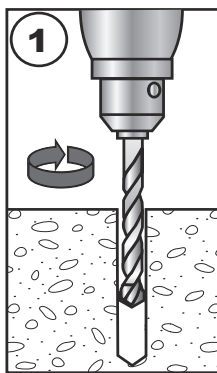

1 Drill hole to the specified diameter and depth. It is advised to over drill the depth by at least 1/2". Do not ream the holes.

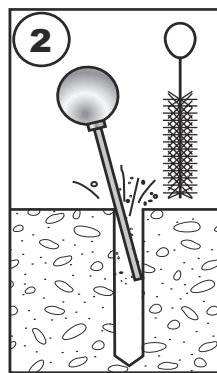

2 Blow out dust from the hole

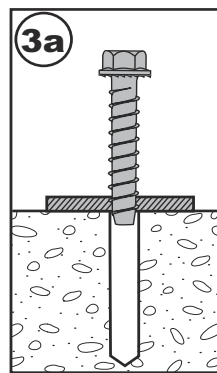

3a Place the anchor through the fixture

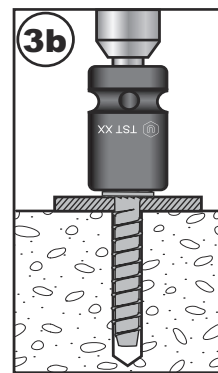

3b Attach the recommended size TST Torpedo® setter to a 1/2" drive impact wrench, place the setter over the head of the anchor and install. Immediately stop when the setter spins/disengages from the anchor's head.

¹ When using impact wrench, there is a risk of over-tightening and damaging the screw, impact tool may not correlate properly with the above setting torques. Over torquing can damage the base material, anchor and/or reduce its holding capacity. If the TST Setter is not used, immediately stop when the bottom of the anchor head comes in contact with the fixture. Use a calibrated hand torque wrench to finish the installation.

► TECHNICAL DATA FOR CARBON STEEL UTB FOR LIMIT STATE / STRENGTH DESIGN IN CRACKED AND UNCRACKED CONCRETE

TABLE 1- TORPEDO BOLT SCREW ANCHOR INSTALATION INFORMATION¹

Characteristic	Symbol	Units	Nominal Anchor Diameter	
			³ / ₈ -inch	¹ / ₂ -inch
Nominal Anchor Diameter	d_a	in (mm)	³ / ₈ (9.5)	¹ / ₂ (12.7)
Nominal Drill Bit Diameter	d_{bit}	in (mm)	³ / ₈ (9.5)	¹ / ₂ (12.7)
Nominal Embedment Depth	h_{nom}	in (mm)	3 (76)	3 (76)
Effective Embedment Depth	h_{ef}	in (mm)	2.30 (58)	2.28 (58)
Minimum Hole Depth	h_{hole}	in (mm)	3 ¹ / ₄ (83)	3 ¹ / ₄ (83)
Fixture Hole Diameter	d_f	in (mm)	¹ / ₂ (12.7)	⁵ / ₈ (15.9)
Maximum Installation Torque	$T_{inst,max}$	ft.lb (Nm)	25 (34)	55 (75)
Maximum impact wrench torque rating	$T_{impact,max}$	ft lb (Nm)	380 (515)	380 (515)
Minimum Concrete Thickness	h_{min}	in (mm)	4 ³ / ₄ (121)	4 ¹ / ₂ (114)
Critical Edge Distance	c_{oc}	in (mm)	5 (127)	4 (102)
Minimum Edge Distance	c_{min}	in (mm)	2 (51)	2 (51)
Minimum Spacing	s_{min}	in (mm)	3 (76)	3 (76)

¹The tabulated data is to be used in conjunction with the design criteria given in ACI 318-(19 and -14) Chapter 17 or ACI 318-11 Appendix D or for Canadian design CSA A23.3-19 Annex D as applicable.

TABLE 2 - RESISTANCE FACTORS FOR LIMIT STATE DESIGN IN ACCORDANCE WITH CSA A23.3-14, ANNEX D

Setting information	Symbol	Units	Nominal Anchor Diameter
			³ / ₈ " and ¹ / ₂ "
Concrete material resistance factor	Φ_C	-	0.65
Steel material resistance factor	Φ_S	-	0.85
Strength reduction factor for tension, steel failure modes	R		0.80
Strength reduction factor for shear, steel failure modes	R		0.75
Strength reduction factor for tension, concrete failure modes	R	Cond. A	1.15
		Cond. B	1.00
Strength reduction factor for Shear, concrete failure modes	R	Cond. A	1.15
		Cond. B	1.00

TABLE 3 - STRENGTH DESIGN DATA IN CRACKED AND UNCRACKED NORMAL WEIGHT CONCRETE^{1,2,3,4}

Characteristic	Symbol	Units	Nominal Anchor Diameter	
			³ / ₈ -inch	¹ / ₂ -inch
Nominal Embedment Depth	h_{nom}	in (mm)	3 (76)	3 (76)
Anchor Category	1, 2 or 3	-	1	1
Steel Strength in Tension and Shear				
Minimum specified ultimate strength	f_{uta}	psi (N/mm ²)	147,000 (1,014)	147,000 (1,014)
Minimum specified yield strength	f_y	psi (N/mm ²)	117,600 (811)	117,600 (811)
Effective stress area (screw anchor body)	A_{se}	in ² (mm ²)	0.103 (66.5)	0.193 (124.5)
Steel Strength in Tension	N_{sa}	lb (kN)	12875 (57.3)	24,125 (107.3)
Strength Reduction Factor for Steel Failure in Tension	ϕ	-	0.65	0.65
Steel Strength in Shear	V_{sa}	lb (kN)	5517 (24.54)	6,570 (29.2)
Steel Strength in Shear, Seismic	$V_{sa,eq}$	lb (kN)	5517 (24.54)	6,570 (29.2)
Strength Reduction Factor for Steel Failure in Shear	ϕ	-	0.60	0.60
Pullout Strength in Tension³				
Pullout Strength in Uncracked Concrete	$N_{p,uncr}$	lb (kN)	-	-
Pullout Strength in Cracked Concrete	$N_{p,cr}$	lb (kN)	-	-
Pullout Strength in Cracked Concrete, Seismic	$N_{p,eq}$	lb (kN)	-	-
Concrete Breakout Strength in Tension				
Effective embedment	h_{ef}	in (mm)	2.30 (58 mm)	2.28 (58)
Effectiveness Factor for Uncracked Concrete	k_{uncr}	-	27	27
Effectiveness Factor for Cracked Concrete	k_{cr}	-	17	17
Strength Reduction Factor for Concrete Breakout Strength in Tension	ϕ	-	0.65	0.65
Axial stiffness in service load range in uncracked concrete	β_{uncr}	lb/inch (N/mm)	246,746 (43,212)	189,880 (33,250)
Axial stiffness in service load range in cracked concrete	β_{cr}	lb/inch (N/mm)	177,965 (31,167)	101,150 (17,715)
Concrete Breakout Strength in Shear				
Nominal Diameter	d_a^2	in (mm)	³ / ₈ (9.5)	¹ / ₂ (12.7)
Load Bearing Length of Anchor	l_e	in (mm)	2.30 (58 mm)	2.28 (58)
Reduction Factor for Concrete Breakout Strength in Shear	ϕ	-	0.70	0.70
Concrete Pryout Strength in Shear				
Coefficient for Pryout Strength	k_{cp}	-	1.0	1.0
Reduction Factor for Pryout Strength in Shear	ϕ	-	0.70	0.70

¹The tabulated data is to be used in conjunction with the design criteria given in ACI 318(-19 and -14) Chapter 17 or ACI 318-11 Appendix D, as applicable.

²All values of ϕ were determined from the load combinations of 2021 IBC Section 1605.1, 2018, 2015 and 2012 IBC Section 1605.2, ACI 318 (-19 and -14) Section 5.3 or ACI 318-11 Section 9.2, as applicable. If the load combinations of ACI 318-11 Appendix C are used, then the appropriate value of ϕ must be determined in accordance with ACI 318-11 D.4.4. For reinforcement that meets ACI 318 (-19 and -14) Chapter 17 or ACI 318 Appendix D, as applicable, requirements for Condition A, see ACI 318-19 17.5.3, ACI 318-14 17.3.3 or ACI 318-11 D.4.3, as applicable, for the appropriate ϕ factor when the load combinations of 2021 IBC Section 1605.1 or 2018, 2015 and 2012 IBC Section 1605.2, ACI 318(-19 and -14) Section 5.3 or ACI 318-11 Section 9.2, as applicable, are used.

³Where no value is reported for pullout strength, this resistance does not need to be considered.

⁴For Limit State Design as per CSA A23.3-19 Annex D, material resistance factors (Φ) and resistance modification factor (R) listed in Table 3 shall be used.